



Star PCB

mas-effects.com/star/

This is a really simple fuzz pedal based on the Bazz Fuss circuit.

It's an amazing platform for experimentation, so be sure to try out some variations of R1 & Q1 to hear some differently voiced fuzzes.



Schematic

NOTE: These are just example values (and my favorites). You DO NOT NEED these specific parts. See the BOM and continue reading for more ideas.

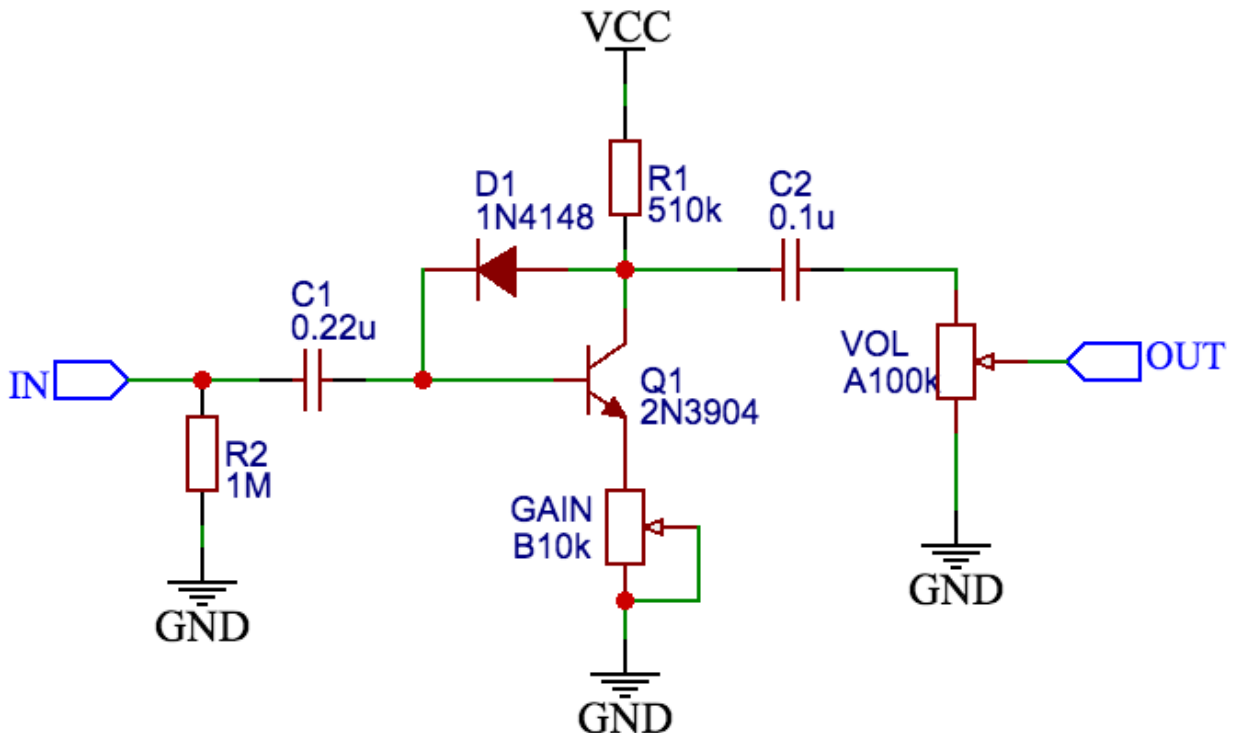

Bill of Materials

Designator	Value	Note
D1	Any diode (including LEDs)	The Vf of the diode will dictate how aggressively it clips, and its type will determine the shape of the clipping.
R1	10k to 510k	Different transistors (Q1) require different values of R1, so you'll need to experiment to find the right combination.
Q1	Try various NPN transistors	2n3904, 2n5088, MPSA13, and plenty of others will work great
C1	0.22uF	Changing this adjusts the cutoff frequency of the High Pass Filter on the input
C2	0.1uF	Exact value isn't terribly important; It primarily removes DC offset
R2	510k to 2.2M	<i>OPTIONAL:</i> Helps to prevent pop
VOL	A100k is traditional, but use what you have	<i>OPTIONAL:</i> This pot helps to bleed some of the signal to ground. If you want to omit, see the notes below.
GAIN	5k to 10k works well, but use what you have	<i>OPTIONAL:</i> This pot can be used to reduce the gain (less fuzz). If you want to omit it, see the notes below.

Here are some example Q1 + R1 pairs to try, but you can and should experiment with whatever transistors you have. Just vary R1 until it sounds good.

R1	Q1
510k	2n3904
100k	2n5088
10k	MPSA13

Transistor Orientation

Note: The silkscreen outline on the PCB corresponds to transistors with legs compatible with the 2n3904 or MPSA13. You can use others, but **you may need to put it in "backwards"** or bend its legs accordingly. Be sure to insert each leg into the correct hole.

They are annotated below for reference.

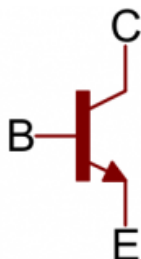

Hookup Guide

View from back of potentiometers

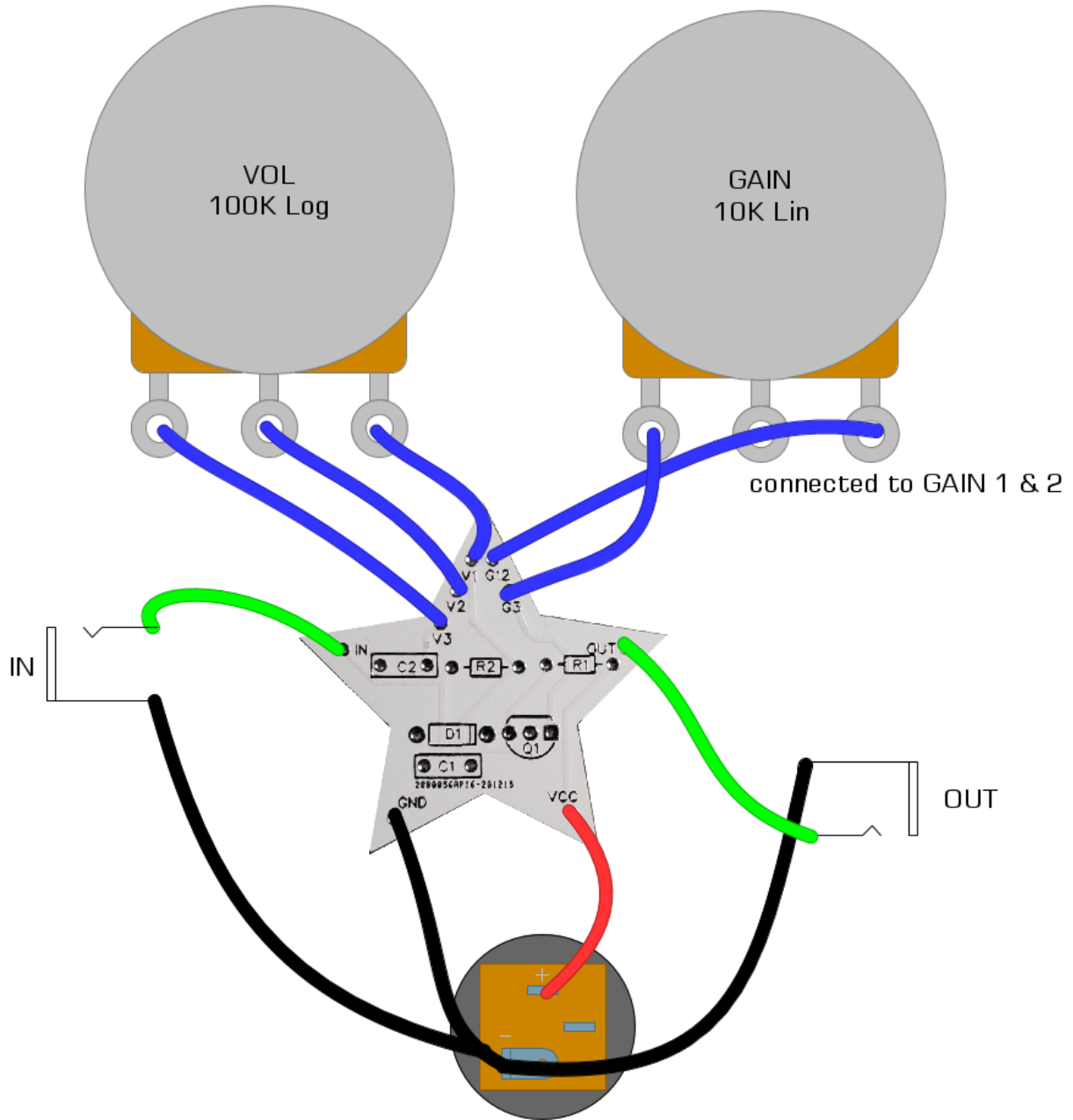

Oh no! It doesn't sound good!?

Don't panic! You simply need a different value of R1 to go with your transistor. Try a 510k, then a 100k, then a 10k. One of these will probably sound good.

Omitting Volume and/or Gain

Volume

You can wire a jumper between V2 and V3 and omit the volume potentiometer to get full volume.

Gain

You can wire a jumper between G12 and G3 and omit the pot to get full gain.



Further Reading

- <http://www.home-wrecker.com/bazz.html>
- <https://www.tonefiend.com/wp-content/uploads/DIY-Club-Project-2-v02.pdf>